

# In-Situ Diagnosis of Vapor-Compressed Chiller Performance for Energy Saving

**Younggy Shin\***

*Department of Mechanical Engineering, Sejong University,  
Seoul 143-747, Korea*

**Youngil Kim**

*School of Architecture, Seoul National University of Technology,  
Seoul 139-743, Korea*

**Guee-Won Moon, Seok-Weon Choi**

*Space Test Department, Korea Aerospace Research Institute,  
Daejeon, Korea*

In-situ diagnosis of chiller performance is an essential step for energy saving business. The main purpose of the in-situ diagnosis is to predict the performance of a target chiller. Many models based on thermodynamics have been proposed for the purpose. However, they have to be modified from chiller to chiller and require profound knowledge of thermodynamics and heat transfer. This study focuses on developing an easy-to-use diagnostic technique that is based on adaptive neuro-fuzzy inference system (ANFIS). The effect of sample data distribution on training the ANFIS is investigated. It is found that the data sampling over 10 days during summer results in a reliable ANFIS whose performance prediction error is within measurement errors. The reliable ANFIS makes it possible to prepare an energy audit and suggest an energy saving plan based on the diagnosed chilled water supply system.

**Key Words :** Centrifugal Chiller, ESCO (Energy Saving Company), Artificial Neural Network, ANFIS, COP, Chilled Water, Dynamics, Diagnosis

## Nomenclature

$A_1, A_2$  : An instance of membership function  
 $B_1, B_2$  : An instance of membership function  
 $COP$  : Coefficient of performance  
 $D$  : A compact space of  $N$  dimensions  
 $f$  : Function  
 $Q_e$  : Cooling load  
 $T_{cwi}$  : Temperature of cooling water at condenser inlet  
 $T_{ewo}$  : Temperature of chilled water at evaporator outlet

$x$  : Input variable to a fuzzy inference system  
 $y$  : Input variable to a fuzzy inference system  
 $\mu_A$  : Bell-shaped membership function  
 $\Psi$  : A set of continuous real-valued functions

## 1. Introduction

Centrifugal chillers with cooling capacity of larger than 200 RT (refrigeration tons) are inevitable necessities for most of office buildings and factories such as clean rooms in semiconductor industry to remove cooling load generated from the buildings. The electric power consumed by such chillers occupies about 20% of nationwide peak electricity demand in Korea, for example

\* Corresponding Author.

E-mail : ygshin@sejong.ac.kr

TEL : +82-2-3408-3284; FAX : +82-2-3408-3333

Department of Mechanical Engineering, Sejong University, Seoul 143-747, Korea. (Manuscript Received January 12, 2005; Revised July 1, 2005)

(Editorial Staff, 2000). Thus, it is expected that any degradation of chiller performance due to aging and negligent maintenance and the like lead to significant increase of nationwide energy cost as well as constructing more electricity power plants. To prevent such losses, it is necessary to diagnose chiller performance accurately and regularly. An ideal diagnosis procedure requires a chiller to run at a standard rating condition, but it is impossible to have a chiller run at the specified condition, because cooling load is not controllable. As an alternative, the performance test at the standard rating condition has been replaced with an approach that combines thermodynamic simulation models and extensive amount of experimental data to determine empirical coefficients employed in the simulation models (Trane, 2005). To make the alternative meaningful, the simulation models should be accurate enough. Enhancing the accuracy requires modeling the whole chilled water system in detail, which complicates the simulation models. Empirical relations employed in a simulation program are based on thermodynamics, heat transfer and experimental data. Because of the empirical features of the relations, model parameters are determined for each specific chiller product model after extensive amount of experiments. Therefore, any simulation work with such scope is possible only in world-leading chiller manufactures. In addition, it is a performance prediction program applicable only to specific chiller models of a manufacturer in concern.

In contrast, from the point of view of customers, what is needed is a performance diagnosis program that is simple and accurate enough to be applicable to all types of chillers. To make such diagnostic tool realizable, the following technical challenges have to be addressed. Firstly, the performance diagnosis should be completed within a few days, if possible, during low-demand seasons like autumn or spring. Secondly, the measurement procedure should be conducted in a non-intrusive way so that a chiller can provide its normal service without getting interrupted. Thirdly, a methodology should be established which extracts quasi-steady state data from mea-

sured ones. Lastly, a performance prediction program should be available which is capable of predicting chiller performance at a standard rating condition. They will be addressed in the study with a special emphasis on proposing the following performance diagnostic tool.

In a response to the need of such simple diagnostic tool, some studies have been conducted to explore possible application of artificial neural network (Swider et al., 2001 ; Palau et al., 1999). A virtue of artificial neural network is its capability of inferring non-linear functional relationship between measured inputs and outputs without resorting to complex physical models. However, identifying the structure of artificial neural network (ANN) requires many parameters and a lot of training data, and the learning time of ANN takes long in general (Jang, 1993). To overcome the shortcomings of ANN, this study suggests a performance prediction program based on the adaptive neuro-fuzzy inference system (ANFIS) that combines artificial neural network and fuzzy logic (Jang, 1993 ; Jang, 1991).

## 2. Adaptive Neuro-Fuzzy Inference System (ANFIS)

System modeling based on conventional mathematical tools (e.g., differential equations) is not well suited for dealing with ill-defined and uncertain systems. On the other hand, a fuzzy inference system employing fuzzy if-then rules can model the qualitative aspects of human knowledge and reasoning processes without employing precise quantitative analyses. This fuzzy modeling or fuzzy identification, firstly explored systematically by Takagi and Sugeno (1985), has found numerous practical applications in control, prediction and inference. However, there has been no systematic way to transform human knowledge or experience into the rule base and database of a fuzzy inference system. In addition, there is a need for effective methods of tuning the membership functions (MF's) so as to minimize the output error measure or maximize performance index. In order to address the problems, Jang (1993) proposed a structure called an adaptive

neuro-fuzzy inference system (ANFIS) based on artificial neural network.

In human recognition, the premise and consequent parts of fuzzy if-then rules are not defined crisply but in linguistic expressions such as large or small. The if-then rules are fuzzified by replacing such linguistic expressions with fuzzy values associated with membership functions. They go through fuzzy inference operations, equivalently corresponding to logical reasoning in human recognition, and the inference reasoning result is defuzzified and presented to an output. Among various types of fuzzy reasoning involved in the defuzzification, the one proposed by Takagi and Sugeno (1985) is employed in constructing ANFIS because its linear consequent part combination of inputs weighed by their consequence parts makes it possible to correlate quantitatively the premise and consequent parts, which is impossible in other reasoning types such as Memdani's (Memdani et al., 1983). The Takagi and Sugeno reasoning can be equivalently expressed in artificial neural network whose capability of self-learning is to be exploit-

ed in the study. Fig. 1 shows the comparison of Takagi-Sugeno type inference system and its equivalent neural network architecture. Therefore ANFIS can be interpreted as a special form of artificial neural network. Using a given input/output data set, ANFIS constructs a fuzzy inference system whose membership function parameters are tuned using either a back-propagation algorithm alone, or in combination with a least-squared method. This allows the fuzzy systems to learn from the data they are modeling.

The parameters associated with the membership functions will change through the learning process. The computation of these parameters is facilitated by a gradient vector, which provides a measure of how well the fuzzy inference system is modeling the input/output data for a given set of parameters. Once the gradient vector is obtained, any of several optimization routines could be applied in order to adjust the parameters so as to reduce some error measure (usually defined by the sum of the squared difference between actual and desired outputs). ANFIS uses either back propagation or a combination of least squares

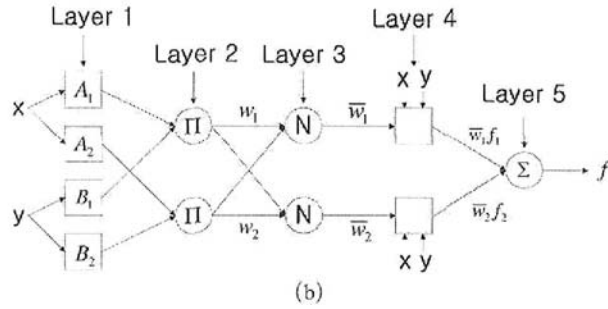
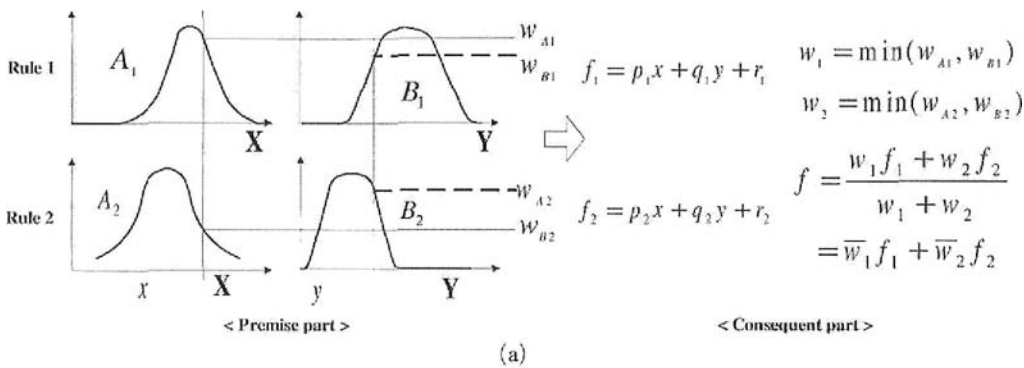

Fig. 1 (a) Takagi-Sugeno Type fuzzy inference system (b) equivalent neural network (ANFIS)

estimation and back-propagation for membership function parameter estimation.

### 3. Experiment

The test chiller for performance analysis is a centrifugal type with the cooling capacity of 200 RT (refrigeration tons). It is one of the three chillers commissioned in 1998 for the special test laboratory with clean room test facilities at the Korea Institute of Science and Technology (KIST) in Korea. Fig. 2 shows one of the chillers. The laboratory is a four-story building with the cooling area of 6655.4 m<sup>2</sup>. The chilled water produced from the chillers is supplied to 2 AHUs (air handling units) for thermal loads from clean room facilities, another 2 AHUs and FCUs (fan coil units) for general purpose labs and offices, as well as to the cooling units of some test equipment. The centrifugal chiller with 2 stage-compressors shows improved performance, compared to the one with a single stage, by expanding the high pressure refrigerant vapor at the condenser exit to a medium pressure between the first and second stages where the vapor of the refrigerant is separated from the liquid phase and sent to the evaporator and the liquid to the inlet of the second stage. The chiller capacity can be varied by controlling the angle of IGV (inlet guide vane) that is installed at the inlet of the compressors to throttle the flow of the refrigerant. The opening angle of IGV is controlled so that the outlet temperature of chilled water is kept



Fig. 2 One of the 200 RT turbo chillers under in-situ measurement

constant regardless of varying cooling load. The coolant that takes heat from the condenser is circulated through the cooling tower to dissipate the heat to the atmosphere by means of evaporation cooling.

Chillers in normal operation should not be interrupted by any work to install sensors. It means that the sensors should be installed in a non-intrusive way. So, temperatures of working fluids flowing through pipes were measured by Pt 1,000  $\Omega$  RTD's (resistive temperature detectors) mounted on the outer surface of the pipes after removing the insulating materials locally at the sensor mounting location. Flow rates of the chilled water and the cooling water were measured using an ultrasonic flowmeter mounted on the outer surface of the pipes as well. Electricity consumption was measured with clamp-on type power meters. Data was sampled at every minute. The sensor signals of flowrate and temperature were collected with a data logger, and transferred to a PC along with raw data from power meters. An application program for data communication, display and final processing was written in LabVIEW<sup>®</sup> of National Instruments Co.

### 4. Data Processing

A prerequisite to construct a reliable ANFIS is the availability of sufficient amount of training data distributed uniformly, in other words unbiased, over the domain of input variables. It is because the ANFIS infers the relationship between the inputs and outputs only from the given data set without any prior knowledge. Therefore, how to precondition and process measured data is the most important step for constructing a reliable ANFIS. Regarding the preconditioning issue specific to the prediction of chiller performance in view of energy saving business, the following three requirements should be resolved. One thing is that there should be sufficient number of unbiased performance data points, whose collection takes long time even up to a whole year depending on the scope of work. The other is that processed data should be steady state values because chiller performance is defined

thermodynamically at steady state. Ideas to resolve the requirements are proposed in the following.

A common practice of conventional studies has been to pick out manually the data points which are judged to be close to steady state (Browne et al., 1998 ; Gordon et al., 1995 ; Bevene et al., 1994). Since it often takes several months, such a practice is plausible only to the realm of academic research. Considering that the purpose of this study is to provide a practical tool for in-situ diagnosis of chiller performance, an efficient method to collect the necessary training data set for a short period should be sought. A clue can be found from the following observation : many thermodynamic-related studies investigating experimental data under steady state to establish a model for chiller performance commonly conclude that the inverse of COP is proportional to the inverse of cooling load  $Q$  as follows (Browne et al., 1998 ; Gordon et al., 1995 ; Bevene et al., 1994). Here, COP is defined as the ratio of cooling load to electricity supplied to a chiller.

$$\frac{1}{COP} = \frac{W}{Q_2} \approx \frac{C_1 + C_2 Q_e}{Q_e} = \frac{C_1}{Q_e} + C_2 \quad (1)$$

This empirical finding provides an essential criterion to filter steady state data from raw data measured from chillers in operation. The next issue is how to low-pass filter the raw data. The raw data itself contains high frequency noises and transient load effects. Thus, the data should be filtered using an appropriate averaging time interval. Since a chiller is in normal operation and its cooling load also changes incessantly, it is not possible to obtain ideally steady state data as desired in research test facilities. Instead, quasi-steady state data can be obtained by time-averaging raw data. In order to extract as many quasi-steady state data as possible from measurements conducted during a short period, average time interval should be short. According to the experimental results of Browne et al.(2000), the first-order dynamic response time of the 200RT single-screw type chiller was about 2 minutes. It means that the averaging time for low-pass

filtering should be at least longer than 2 minutes. In this study, the time interval was varied from 5 minutes to 60 minutes by 5 minutes to determine optimal one that is short, but doesn't deteriorate quality of quasi-steady state data. The interval swing test suggested that 10 minutes be the most plausible candidate, considering that it is about 5 times the dynamic response time and that its averaged data set is quite similar to the ones averaged for longer intervals. Part of the averaged data, however, is still different from the rest, because the data averaged during starts and stops quite often deviates from steady state ones. To exclude such unsteady data, the following criteria were applied :

(1) When outlet temperature of chilled water goes beyond the range of the design operation temperature (for the test chiller, 7.5°C) +0.5°C or so.

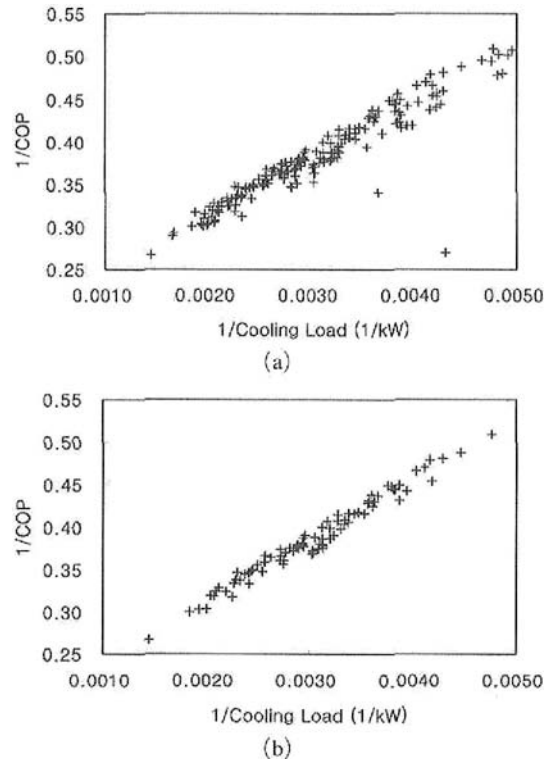

**Fig. 3** 10 minutes-average data points sampled during June 1st, 3rd, 5th and 7th of 2000 (b) data points that meet the quasi-steady state criteria among the data points of (a)

(2) When averaged data deviates from the linearity of the empirical thermodynamic relation (1).

Fig. 3 represents the relationship between COP and cooling load for 10 minutes-averaged data logged during the four days (June 1<sup>st</sup>, 3<sup>rd</sup>, 5<sup>th</sup> and 7<sup>th</sup>). Fig. 3(a) shows all the data obtained during the period, and Fig. 3(b) shows only the data that meet the criteria of quasi-steady state.

## 5. ANFIS-Based Prediction Model of Chiller Performance

According to the studies to refine the empirical relation (1), it is closely related with coolant inlet temperature  $T_{cwi}$  and chilled water outlet temperature  $T_{ewo}$ . On the other hand, coolant outlet temperature and chilled water inlet temperature, which are also important as much, are generally dismissed, because their effects are already reflected in cooling load and the efficiency of heat exchangers. Therefore, the fuzzy model based on ANFIS is assumed to take the following form:

$$1/COP = f(1/Q_e, T_{cwi}, T_{ewo}) \quad (2)$$

More input parameters could be added, but it will increase computational burden in geometric progression. So it is recommended to keep a minimal number of input variables as far as the effect of an additional input variable is marginal. The prediction model of this study is intended to be expressed in the parameters that can be measured with ease on the site. In that respect, the relation (2) is appropriate to the view of the current study. The input variables in Equation (2) constitute  $x$  and  $y$  in Fig. 1(a). For fuzzy reasoning, a membership function such as  $A_1$ ,  $A_2$ ,  $B_1$ , and  $B_2$  in Fig. 1 (a) is needed. It should satisfy the following requirements.

For the domain  $D$ , which is a compact space of  $N$  dimensions, the fuzzy inference system  $\Psi$ , a set of continuous real-valued functions, has unlimited approximation power to match any nonlinear functions arbitrarily well on a compact set, if it satisfies the Stone-Weierstrass theorem (Kantorovich et al., 1982) stated below.

**Identity Function:** The constant  $f(x) = 1$  is in  $\Psi$ .

**Separability:** For any two points  $x_1 \neq x_2$  in  $D$ , there is an  $f$  in  $\Psi$  such that  $f(x_1) \neq f(x_2)$ .

**Algebraic Closure:** If  $f$  and  $g$  are any two functions in  $\Psi$ , then  $fg$  and  $af + bg$  are in  $\Psi$  for any two real numbers  $a, b$ .

For the first and second criteria, it is trivial to find simplified fuzzy inference systems that satisfy them. However, in order to meet the third criterion, the membership function should be bell-shaped (Jang, 1993). It could be either Gaussian membership function or the following bell function with three tuning parameters.

$$\mu_A(x) = \frac{1}{\left(1 + \left|\frac{x-c}{a}\right|\right)^{2b}} \quad (3)$$

In general, there is no specific rule for construction of an ANFIS to approximate given system characteristics. In this study, the bell function (3) is preferred because it provides more degrees of freedom to shape a membership function. The number of input variables is 3, as suggested by Equation (2), and each variable is set to have two membership functions. When three membership functions were allowed to each input variable, the resulting ANFIS was found to tend to over-fit the chiller performance. Since the relationship between COP and input variables was nearly in linear proportion according to the empirical relations based on thermodynamics (Browne et al., 1998; Gordon et al., 1995; Bevene et al., 1994, 2000), two membership functions were assigned accordingly to each input variable, and thereby the errors between the model and the experiment could be reduced, compared to the case of three membership functions. The resulting ANFIS architecture is shown in Fig. 4.

In Fig. 4, the number of fuzzy rules is  $2^3 = 8$  and the number of nodes is 34. The number of nonlinear parameters associated with the membership functions of the premise part (nonlinear bell function) is  $6 \times 3 = 18$ , and the number of linear parameters in the consequent part by the Sugeno-type linear inference engine is  $8 \times 4 = 32$ .

Training ANFIS means to determine optimal values of the 50 parameters from a given data

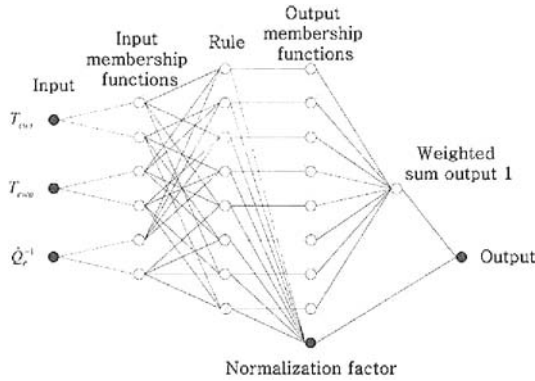

Fig. 4 The ANFIS architecture for the prediction of chiller performance

set. The hybrid training algorithm employed in ANFIS determines linear parameters in the consequent part first by the least square method, and then back-propagates the slope of the errors calculated by the linear parameters to the premise part where the nonlinear parameters are calculated by the gradient descent technique. The calculation procedure is repeated until either the final errors meet design criteria or the number of iterations reaches a set number.

### 6. Training ANFIS

Although it is ideal to have an unbiased training data set that is distributed uniformly over the domain of input variables, it is seldom the case

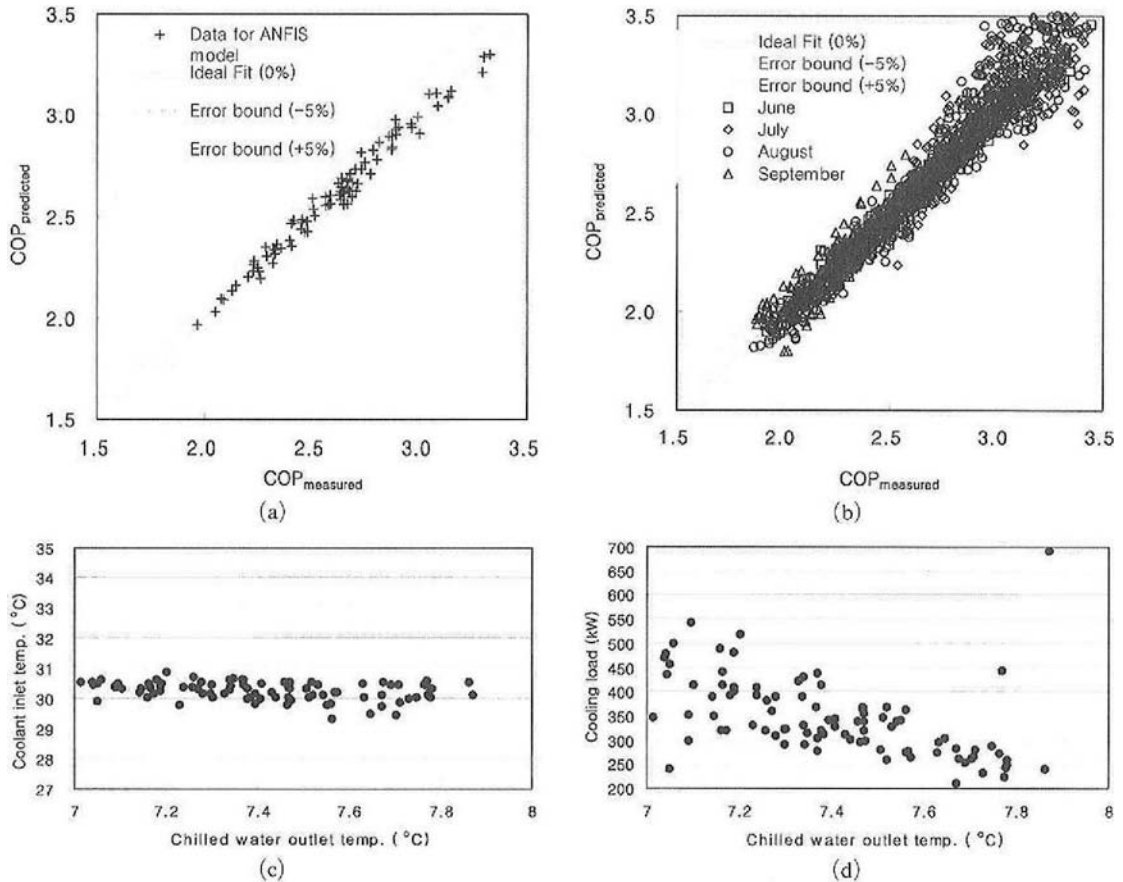
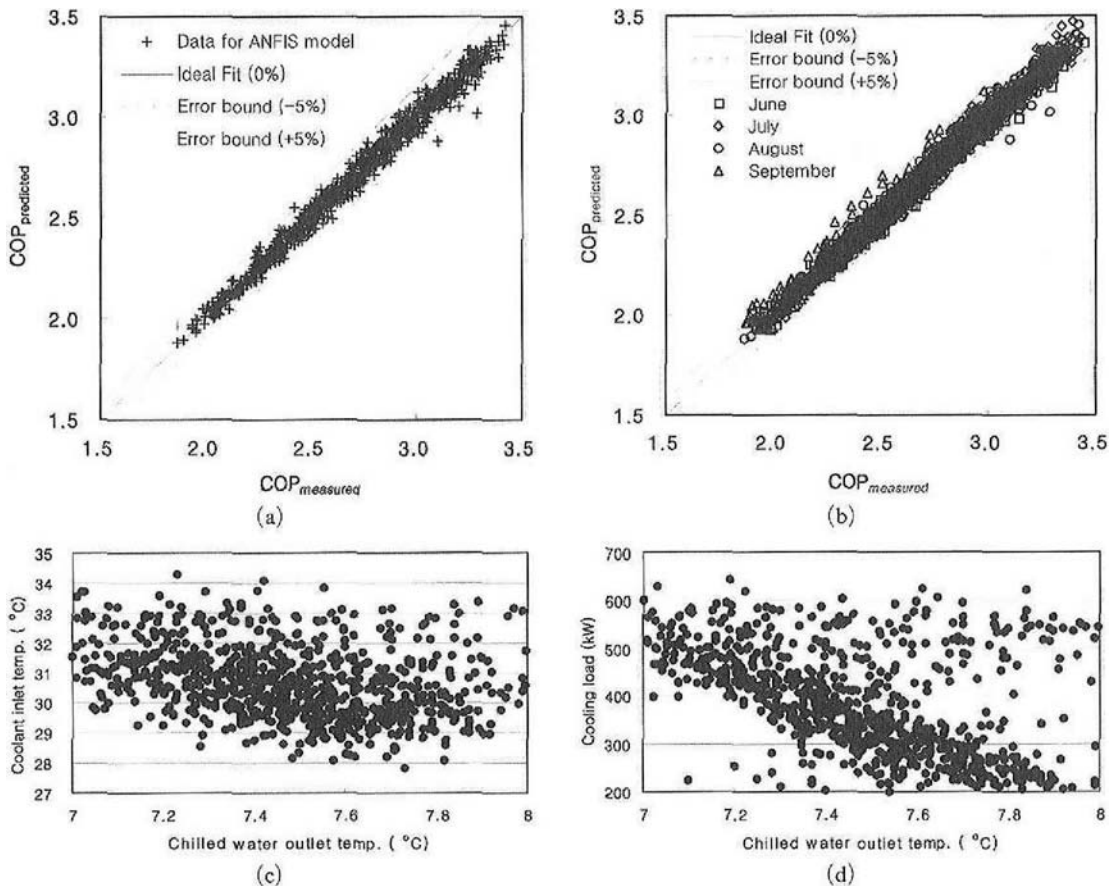

Fig. 5 ANFIS trained with the data sampled during June 1st, 3rd, 5th and 7th of 2000: (a) Fitting performance, (b) prediction performance, (c) data distribution:  $T_{cwo}$  vs.  $T_{cwi}$ , (d) data distribution:  $T_{cwo}$  vs. cooling load

in reality. Instead, there should be a criterion to build a data set that is enough to construct a reliable ANFIS. The criterion specific to chiller performance will be set up empirically by comparing the performance of ANFIS with respect to training data sets. In view of ESCO, it is preferred to diagnose chiller performance during a low-demand season such as spring. During such seasons, however, cooling load on the evaporator side is too low for a chiller to go through all the range of loads. Without a data set distributed over the whole spectrum of the chiller load, it is impossible to obtain a reliable ANFIS as will be exemplified later. In this study, the criterion to build a feasible data set is investigated using the data sets collected from June through September

of Year 2000 at Seoul in Korea.

Fig. 5(a) shows the fitting performance of the ANFIS model trained with the data set collected during the four days of early June. It is seen that the approximation errors are within  $\pm 5\%$ . Thus the ANFIS is the best fit, considering that the measurement error analyzed by the Klein and McClintock's method, as stated before, is about 5%. Using the trained ANFIS model, the chiller performance was predicted for the period of June through September and compared with the experimental data as shown in Fig. 5(b). It is observed that the prediction errors are sort of higher than  $\pm 5\%$  in general and increase significantly at the region of high cooling load (represented by high COP). Comparison of Fig. 5(a) and (b)



**Fig. 6** ANFIS trained with the data sampled during 18 days in August of 2000: (a) Fitting performance, (b) prediction performance, (c) data distribution :  $T_{ewo}$  vs.  $T_{cwo}$  (d) data distribution :  $T_{ewo}$  vs. cooling load



reveals that the increase of errors in the high load region is ascribed to the poor prediction of the ANFIS trained with insufficient data in the high load region as manifested in Fig. 5(c) and (d). Fig. 5(c) and (d) show the distribution of the training data over the domain of input variables. The deficiency of high load data points results from the fact that the chiller was rarely operated at high loads since cooling load demand was low in early June. To confirm the quality problem of training data set, the ANFIS were trained at this time with the data set obtained during 18 days of August. And its prediction performance is shown in Fig. 6. Fig. 6(a) represents the fitting performance of the ANFIS which is within  $\pm 5\%$ . In this case, however, the training data shows relatively uniform distribution over the cooling load or equivalently COP, compared to the case of Fig. 5(a). As expected, the ANFIS trained with the well-distributed data set resulted in the superior prediction performance of Fig. 6(b) in which the prediction errors for the four-month data set are well within 5%. The relatively uniform distribution of the training data over the input domain in Fig. 6(c) and (d) corroborates the argument. Expecting a training data set that shows ideally even distribution over the domain, however, is not possible in chillers, because they are internally constrained to behave in a certain

fashion, for example to control chilled water outlet temperature. The distribution pattern shown in Fig. 6(c) and (d) reflects such temperature control efforts by the chiller controller. Therefore, a prior settlement to construct a reliable ANFIS is to identify such biased pattern of data distribution. Once it is found as in this study, it could be applied to similar kind of chillers because they may present similar biased behavior. To confirm the observation, several cases were investigated for the data sets during June through September. The results are shown in Figs. 7 to 9.

Investigation of Fig. 5 through 9 reveals the following. As far as training data are collected enough to represent the whole spectrum of cooling load, the ANFIS performance becomes reliable, as is the case in Figs. 6, 7 and 8. On the other hand, when data points are not sufficient at high load as in Figs. 5 and 9, the ANFIS becomes less reliable. In both cases, biased training data sets themselves do not become an issue, because they are all subject to the same biased condition caused by the same chiller controller.

The development of internet technology makes it possible to monitor the progress of data acquisition in a remote location and evaluate the quality of the training data set. Acquired data are averaged over 10 minutes and accumulatively plotted against COP and input parameters until

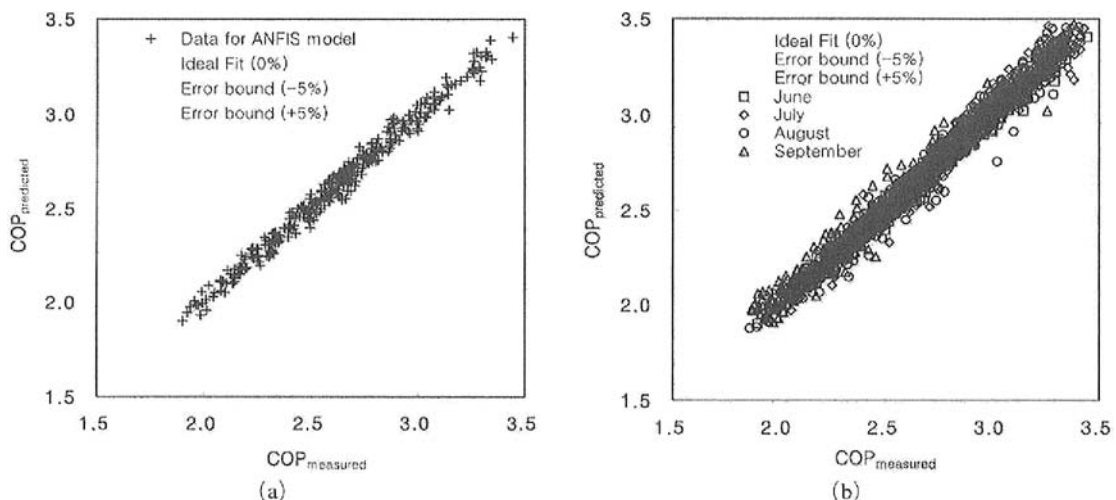

**Fig. 7** ANFIS trained with the data sampled during 13 days in June of 2000 :  
(a) Fitting performance, (b) prediction performance

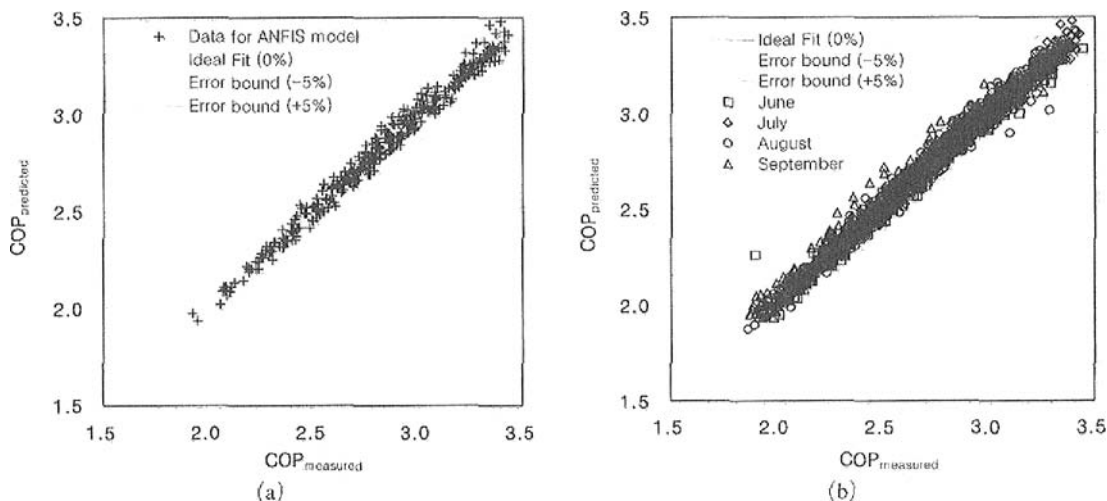

**Fig. 8** ANFIS trained with the data sampled during 10 days in July of 2000 :  
 (a) Fitting performance, (b) prediction performance

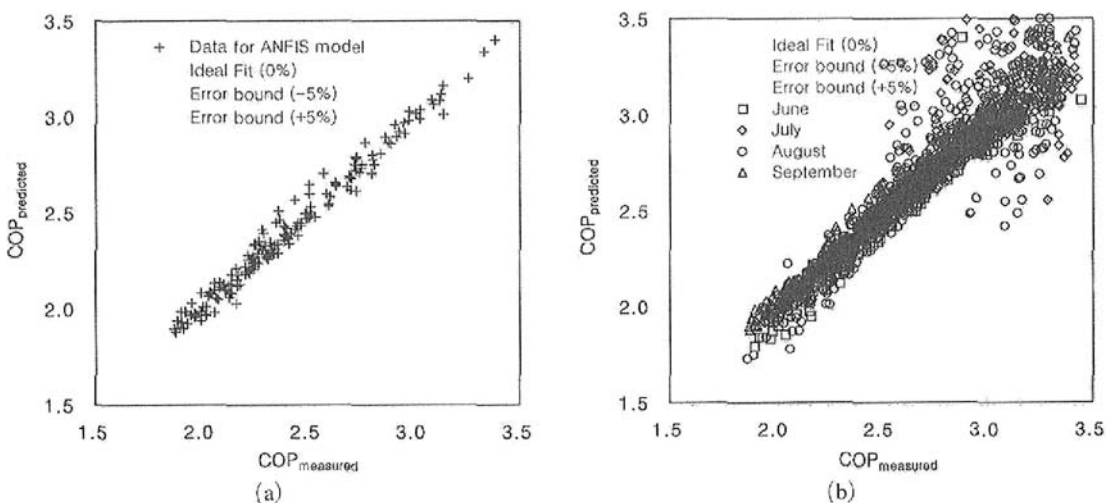

**Fig. 9** ANFIS trained with the data sampled during 10 days in September of 2000 :  
 (a) Fitting performance, (b) prediction performance

the data points are spread out evenly over the range of load in interest. Accumulation of data sets over many chillers would lead to the creation of a reliable algorithm that will automate the process of training data acquisition.

### 7. Prediction of Chiller Performance with an ANFIS Model

The chiller performances predicted by the ANFIS are now compared at the standard rating

condition set by Korea Industry Standard (1985). The details are specified in Table 1.

Fig. 10 shows the comparison of performances at the condition predicted by the ANFIS trained with the data sets shown in Fig. 4 through 8. As expected, the poor ANFISs of Figs. 5 and 9 also led to different performance prediction at the standard rating condition, compared to the others. The performance curves predicted by the reliable ANFIS of Figs. 6, 7 and 8 were found to be in good agreement with the experimental

**Table 1** Refrigerator rating condition set by Korea Industry Standard

Operation	Chilled water temperature ( $\gamma\phi C$ )		Cooling water temperature ( $\gamma\phi D$ )	
	In	Out	In	Out
Full load	12	7	32	37
Part load	*	7	**	*

\* The flow rates are to be held constan at full load values for all part load conditions

\*\* The temperature should vary linearly from 32  $\gamma\phi C$  to  $\gamma\phi C$  for 100% to 0% load

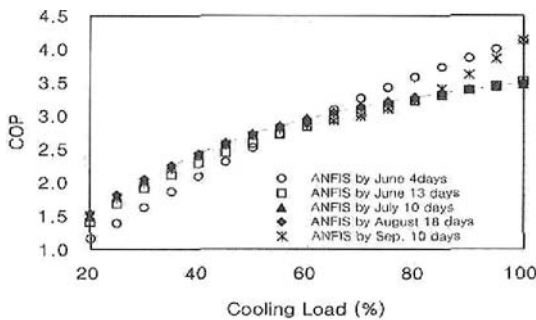

**Fig. 10** Comparison of COP predicted at the standard rating condition according to ANFIS trained over June through September 2000

data that were under steady state at the standard rating condition. The meaning of the performance curve in Fig. 10 is quite straightforward. The predicted COP can be directly compared with those of other comparable chillers in view of chiller diagnosis. And the COP also can be used to estimate energy cost to remove cooling load from a target building.

## 8. Conclusions

The merits of the constructed ANFIS are largely two-fold. Firstly it can be used as a simulation model of the chiller under diagnosis to estimate its operation cost. Secondly, it can be applied as a diagnostic tool to determine whether the chiller needs overhaul for energy saving or not. From the study to develop the ANFIS algorithm for the prediction of chiller performance, the following conclusions were obtained :

- (1) It is possible to extract quasi-steady state

data from the chiller in normal operation by considering the empirical knowledge of operation ranges of chiller water temperatures and the linear relationship between  $1/COP$  and  $1/Q_e$ . And the averaging time interval was found to be at least larger than 10 minutes.

(2) How to design the structure of the ANFIS should be considered in conjunction with the empirical knowledge about the system in concern. The appropriate number of fuzzy rules per input was two from the behavior of the empirical thermodynamic relation. More than 2 led to over-fitting tendency of the experimental data.

(3) Training data set is inevitably biased over the input domain due to the constraints imposed on a chiller, for example to control temperatures. However, the influence of the bias on the ANFIS training is mitigated from the observation that the same bias is applied to all loads.

(4) It is suggested that the data collection be made at least over 10 days during summer. During the seasons other than summer, there exist increasing chances of missing data points in the high load region, which will deteriorate the reliability of the trained ANFIS. For a well-trained ANFIS, the prediction error is within  $\pm 5\%$  that is comparable to measurement error bounds.

## Acknowledgments

Authors wish to acknowledge that this work was supported by COMS-1 (Communication, Ocean and Meteorological Satellite) Project.

## References

- Beyene, A., Guven, H., Jawdat, Z. and Lowrey, P., 1994, "Conventional Chiller Performances Simulation and Field Data," *International Journal of Energy Research*, Vol. 18, pp. 391~399.
- Browne, M. W. and Bansal, P. K., 1998, "Steady-state Model of Centrifugal Liquid Chillers," *International Journal of Refrigeration*, Vol. 21, No. 5, pp. 343~358.
- Browne, M. W. and Bansal, P. K., 2000, "Modelling of In-Situ Liquid Chillers," *Eighth International Refrigeration Conference at Purdue*

University, pp. 425-432, West Lafayette, IN, USA

Editorial Staff, 2000, "Campaign for Green Energy Family," *Monthly Issue of Building Equipment*, No. 135, pp. 110~121. (written in Korean)

Gordon, J. M., Ng K. C., and Chua, H. T., 1995, "Centrifugal Chillers: Thermodynamic Modelling and a Diagnostic Case Study," *International Journal of Refrigeration*, Vol. 18, No. 4, pp. 253~257.

Jang, J. -S. R., 1993, "ANFIS: Adaptive-Neural-network-based Fuzzy Inference Systems," *IEEE Transactions on Systems, Man, and Cybernetics*, Vol. 23, No. 3, pp. 665~685.

Jang, J. -S. R., 1991, "Fuzzy Modeling Using Generalized Neural Networks and Kalman Filter Algorithm," *Proc. of the Ninth National Conf. on Artificial neural network (AAAI-91)*, pp. 762~767.

Kantorovich, L. V. and Akilov, G. P., 1982, "Functional Analysis," second edition, Oxford, UK: Pergamon

Korea Industry Standard, 1985, "KS B 6270-85 Centrifugal Refrigerator," Agency of Technology

and Standards.

Mamdani, E. H., Ostergaard, J. J. and Lembessis, E., 1983, "Use of Fuzzy Logic for Implementing Rule-based Control of Industrial Processes," *Advances in Fuzzy Sets, Possibility Theory, and Applications*, Plenum Press, pp. 307~323.

Palau, A., Velo, E. and Puigjaner, L., 1999, "Use of Neural Networks and Expert Systems to Control a Gas/Solid Sorption Chilling machine," *International Journal of Refrigeration*, 22 (1), pp. 59~66.

Swider, D. J., Browne, M. W., Bansal, P. K. and Kecman, V., 2001, "Modelling of Vapour-Compression Liquid Chillers with Neural Networks," *J. of Applied Thermal Engineering*, Vol. 21, pp. 311~329.

Takagi, T. and Sugeno, M., 1985, "Fuzzy Identification of Systems and its Application to Modeling and Control," *IEEE Transactions on Systems, Man & Cybernetics*, Vol. 15, 116~132.

Trane, 2005, "TRACE 700 Chiller Plant Analyzer," <http://www.trane.com>.